

# A Design Method of Remote Control System and Its Application in Greenhouse

Yongqiu Liu<sup>a</sup>

Guangdong University of Science and Technology, Dongguan 523083, China

<sup>a</sup>banbianqiu@126.com

**Abstract.** Sophisticated wirings have many defects such as poor stability, difficult to install and maintain with traditional method, a remote intelligent control system which has multi-parameter, low-cost, integrated of measurement and control is developed for greenhouses by using the ZigBee technology. The general structure, its hardware design and software implementation are presented in this paper. With the physical greenhouse-models, the proposed system is tested. The evaluation results showed the designed system obtained effective control performance with low power consumption, strong mobility and stability, the measured data can be uploaded to the PC for display in real-time.

**Keywords:** Greenhouse, Control system, Remote monitoring.

## 1. Introduction

The greenhouse environment monitoring system has a rapid development due to the wide application of computer technology, which urges the improvement of its modernization level greatly<sup>[1-2]</sup>. Traditional greenhouse monitoring system is mainly concentrated on wired communication, there comes the problems of high cost, poor scalability, difficult to maintain and certain effect is caused on crop cultivation, those phenomenon are widespread under the control system of large-scale greenhouses. To deal with these scenarios, Du Hui et al, proposed a greenhouse monitoring system based on Bluetooth technology<sup>[3]</sup>, Shen Dili et al, reported a greenhouse monitoring system using the Wi-Fi technology<sup>[4]</sup>. The above problems are solved to some extent, but the high cost still exists.

A remote intelligent control system is designed in this paper which has multi-parameter, low cost, integrated of measurement and control by using the ZigBee technology that can solve the above problems perfectly. In order to realize that, the system acquires parameters under the greenhouse environment (this paper focuses on temperature, soil humidity, light intensity) by using the route modules and sends them to the Coordinator of ZigBee (CZB), uploads them to the PC through RS232 serial port<sup>[5]</sup> after processing, then the PC sends control commands to the Terminal Nodes of ZigBee (TNZB) through CZB to control corresponding equipment to automatically adjust the relevant environmental parameters.

The novelty of the system lies in the following respects:

The interface of PC provides two types of working: automatic mode and manual mode. The former can facilitate the intelligent management, while the latter is convenience for the staff to crop fertilization, weed control etc. Combination of these two together makes the system more humanization.

CZB is able to complete the monitor to serial port message of PC and to wireless message from the terminal.

Terminal module can simultaneously detect the parameters then send wireless message and monitor the radio message from the coordinator

## 2. General structure of remote control system

The architecture of ZigBee-based mesh network greenhouse management was built to make the system with stronger adaptability, higher stability, removed the influence of geographical environment to the greatest extent, maximally avoided the effect of local fault on the normal work of the entire network [6]. Composed of PC, router, coordinator, terminal module, the sensor node and execute module, the system uses the low voltage to control the high voltage on and off by the connection between terminal module and Solid State Relay (SSR) [7]. As shown in Fig. 1 (take two greenhouses for example).

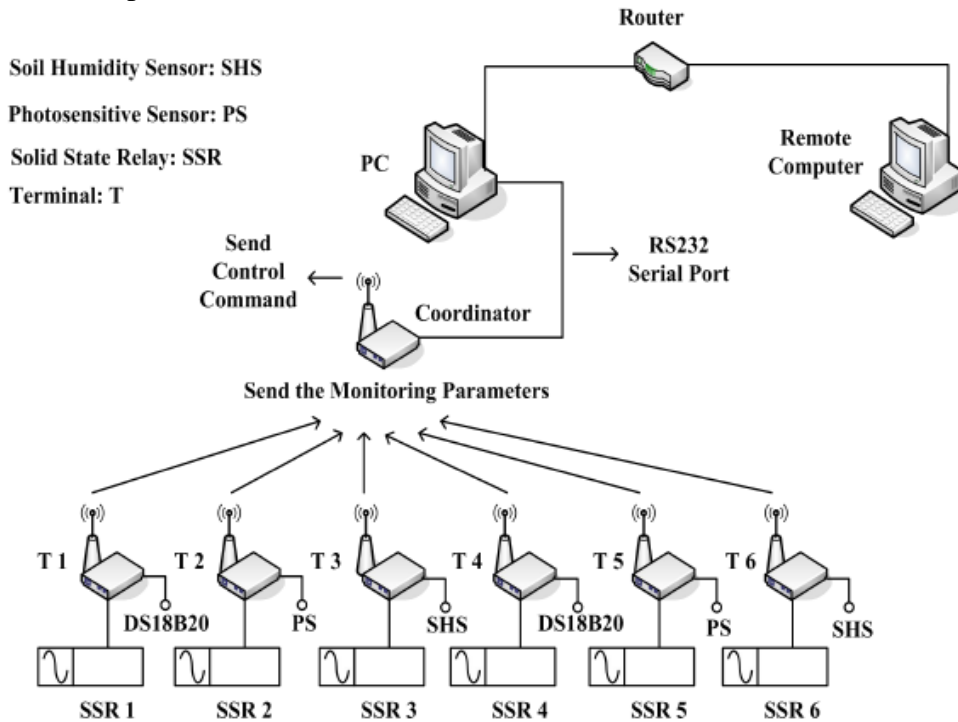

Fig. 1 The principle drawing of the system

PC connects with the remote computer through a router so as to realize the communication with each other. The parameters are obtained by route modules then send to CZB for process, from RS232 serial port to the PC for display. PC analyzes the data to determine whether it is in the range of parameter that suitable for plant growth, if not, send control commands to TNZB through CZB to regulate the corresponding equipment operation.

### 3. Design of hardware system

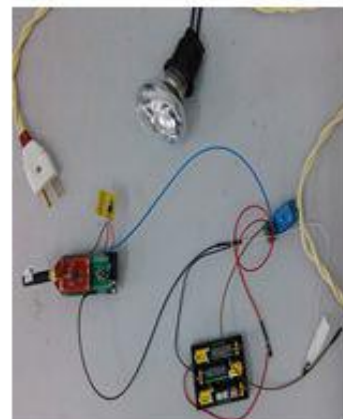
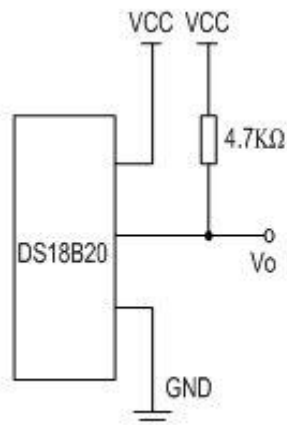

Fig. 2 The diagram of circuit design and terminal physical connection for DS18B20

The design of hardware is mainly aimed at terminal sensor modules, each terminal node revolves around CC2530 [8], then connect related actuators through SSR. Take DS18B20 temperature sensor as the temperature acquire part which has strong anti-interference ability, small volume, convenient to use, intuitive and accurate, and can convert temperature signals directly into serial digital signals

under the  $\pm 0.5^{\circ}\text{C}$  measurement precious [9]. The temperature measurement program is written in the application layer, and defines it as user task, use timer 1 which the module carries to timing and collect the temperature data every few seconds. For the convenience of setting up the experimental system, the bath bully bulb was used as the greenhouse heating equipment. The diagram of circuit design and terminal physical connection are shown in the Fig.2.

Photosensitive sensor itself is a photosensitive resistance which determines its resistance value according to the light intensity. The diagram of circuit design and terminal physical connection are shown in the Fig.3.

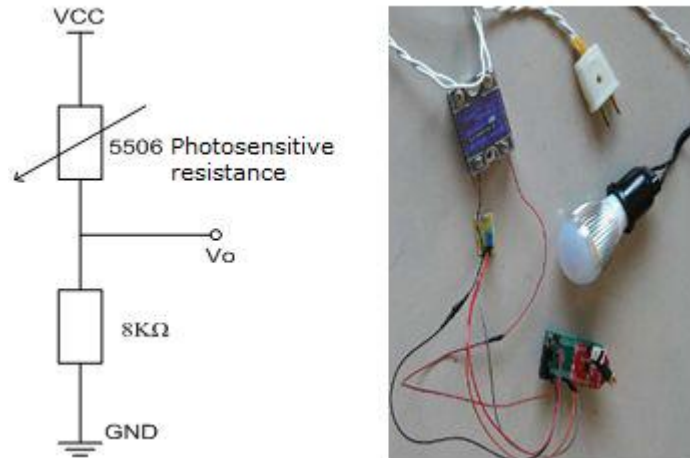

Fig. 3 The diagram of circuit design and terminal physical connection for photosensitive sensor

After testing photosensitive sensor, its resistance value is a few ohms under hard light; while under the weak light is more than  $20\text{ K}\Omega$ . Pick up the voltage output termination of DS18B20 on the P0\_7 pin of CC2530, detects the change of light intensity through its internal A/D converter chip. This paper use illumination as the lighting equipment.

FC-28 was adopted as soil humidity sensor, the miniature DC diaphragm pump PLD-1205 as the terminal actuator. Pick up the voltage output termination of FC-28 on the P0\_7 pin of CC2530, detects the change of soil humidity through its internal A/D converter chip. The diagram of circuit design and terminal physical connection are shown in the Fig.4.

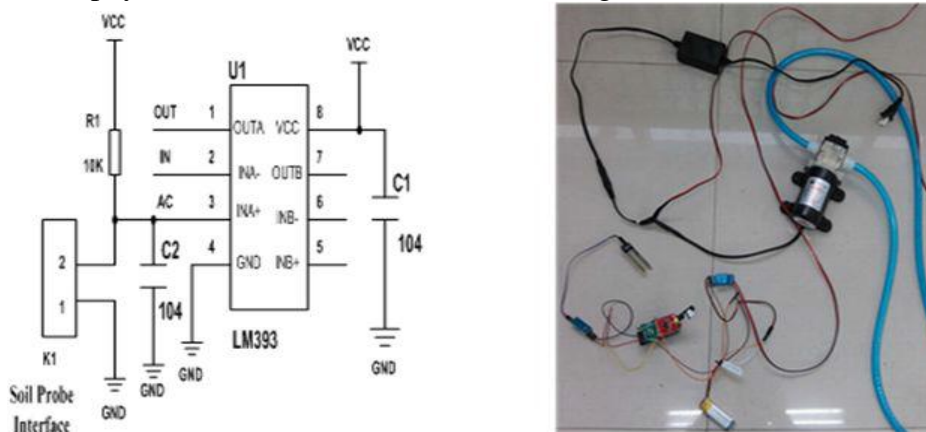

Fig. 4 The diagram of circuit design and terminal physical connection for humidity sensor

#### 4. Design of software system

The design of PC interface program, the coordinator module program and the route module program are included in the design of software. PC interface program uses the MFC framework which among Visual C++ 6.0 platform to design the interface of dialog box. ZigBee protocol Stack (Z-Stack) needs to be transplanted in the program design of CZB and route module under the IAR platform, especially the implementation of PHY layer and MAC layer that closely relates to the underlying hardware, which provides the API interface function for the upper communication application.

#### 4.1 Design of PC interface.

The design of PC interface includes port selection, pattern selection, open/close the serial port button, allowing remote control button, the IP address control, the edit box of parameter display and radio button to send orders.

The function of port selection makes users more convenient to choose on various computers or computer on different ports, which also enhances the flexibility and portability of the interface application. The application has a wide universality by using the serial communication port.

Mode selection falls into two types: automatic mode and manual mode. Automatic mode provides intelligent manage, the system can collect data automatically, then centralized to display and process. Under this mode, PC receives information from terminal through CZB, separates the addresses and parameters that detected by terminal after analysis and process, then displays in the interface. Meanwhile, analysis whether the data meet the definition range of parameters in the system, if not, CZB sends a command message to terminal to perform the corresponding command. Manual mode is to facilitate staff to crop fertilization, weed control etc, in case of inconvenience to the staff under automatic mode.

The system will initialize some functions of the serial port operation, such as set the port number, the receive/send buffer size, trigger threshold of receiving data, buffer reset operation etc. when clicking to open the serial interface button. After clicking, the system begins to receive the data that serial port sends and displays in the corresponding edit box. With the close serial interface button clicked, the system will close serial port, which led to the data cannot be received and deposited in the buffer. Fig.5 is the interface of PC display.

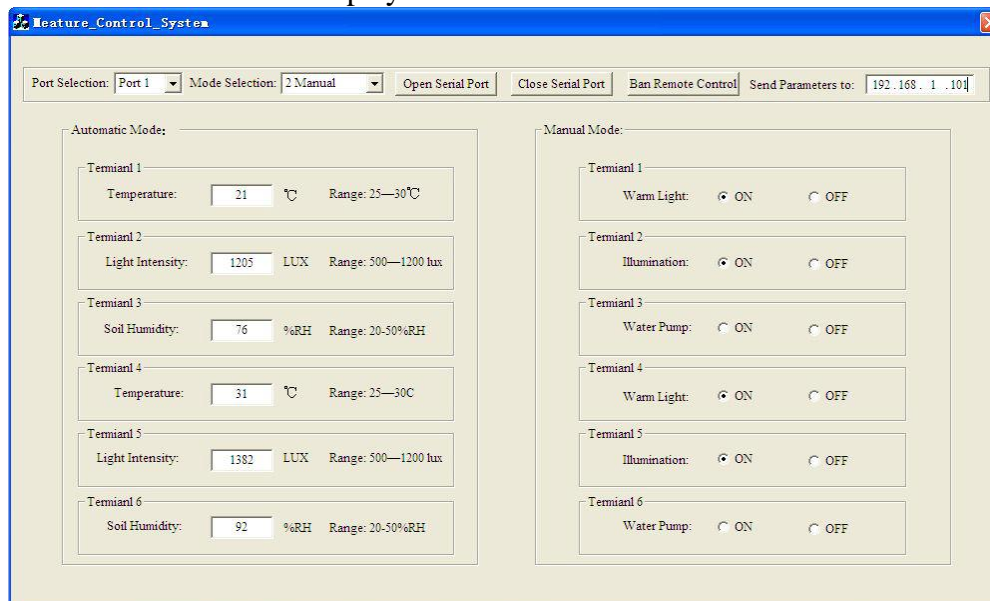

Fig. 5 The interface of PC display

PC connects to the remote computer through a router so as to realize the communication between the computers in the LAN. Input the corresponding IP address in the IP address control, the computers that synchronous reveal the parameters which PC displayed and can control the PC under the circumstance that the PC allows remote control. As shown in Fig.6.

#### 4.2. Design of CZB module program.

CZB, a bridge between PC and various modules communication, which collects the information and then transmits them, plays a pivotal role in the whole system. Physical diagram is shown in Figure 7 (a). It is able to complete the monitor to serial port message of PC and to wireless messages from the terminal.

The design of the program includes communicate with route module through wireless and communicate with PC via serial port line. After receiving the news from the route module, the CZB module encodes the message and sends the encoded message to the PC via a serial port. Among them, the message that received is processed by the interrupt program in CC2530 chip. The serial

communicate part uses the DMA [10] which allows the CPU to process information at a convenient time, and thus minimizes the interruption of the CPU load. Different method can be used in different system, greenhouse is just like that of astronautic when control system is designed[11].

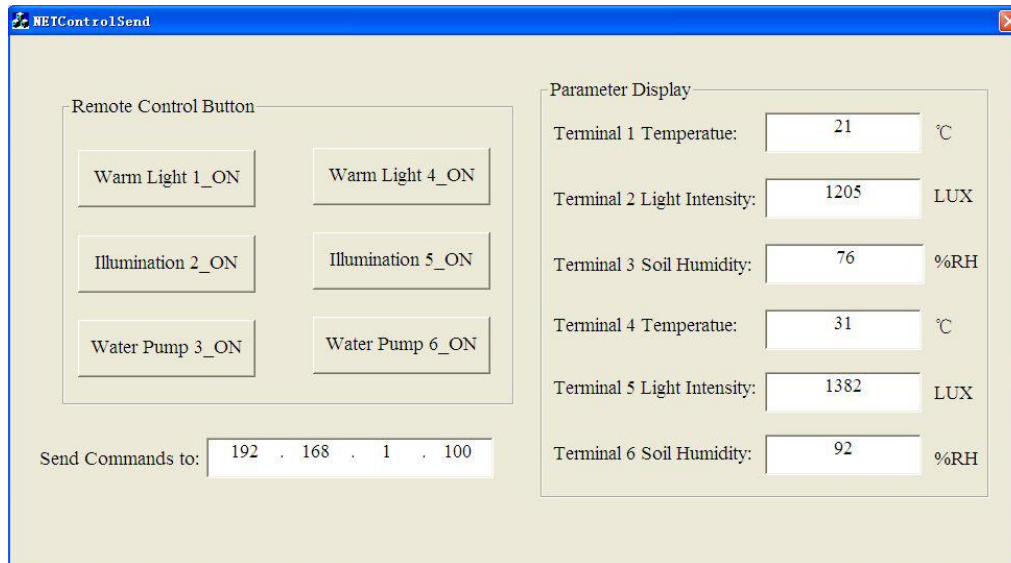

Fig. 6 The interface of the computer that connected with PC

#### 4.3 Design of route module program

Route module programs mainly include three parts: the design of temperature measure, light intensity measure, and soil humidity measure. The program of temperature measuring part which has strict timing requirements is a little more complicated. The principle of metering light intensity and soil humidity are the same, which both use the A/D converter that inside CC2530 chip to transform the analog quantity to digital, then read them. Part of the codes as shown below:

```
void InitialAD(void);//ADC converter inside CC2530,
initialize function declaration.
TempFlag++;//Time stamp.
if(TempFlag == 5)// Sampling interval about 5s.
{
TempFlag = 0;//Empty time stamp.
for(int i=0;i<4;i++)//Into four loops.
{
InitialAD(); //Initialize ADC.
while(!(ADCCON1&0x80));//Wait until the
conversion is complete.
if(ADCCON1&0x80)//If completed, perform
the following tasks.
{
adc = ADCH;
adc = ~adc;//----->By complement for
original code.
adc = adc&0x7f;
ADCCON1 = 0X30; //Stop A/D.
}
}
SampleApp_SendFlashMessage( (uint16)adc |
(5<<8) );//----->Midify the ID number of
terminal routes.
}
```



## 5. Experimental tests

For the restrictions in experimental conditions, the system takes two simulated greenhouses for example to measure the temperature, soil humidity and light intensity. Convenience for setting up the system without affecting the experimental effect, adopting the bath bully lamp as heating device, the illumination as lighting equipment, water pump uses the miniature DC diaphragm pumps PLD-1205. Decorate each greenhouse with three route modules to obtain the parameters of temperature, light intensity, soil moisture, and send them to the CZB for process, after that, via a serial port uploads them to PC interface for display. PC analysis and process the data, and then sends the commands to the corresponding route module by CZB.

For example, the terminal 3 was used for detecting soil humidity. The parameter was transmitted to PC when it was not within the optimal range 20-50%RH, then sent the commands of open pump. Meanwhile, started timing 30 seconds, in this period, PC would not detect soil humidity parameter for processing any more, in case the pump watering inadequacy.

By using ZigBee technology, this paper designs a remote intelligent control system which has multi-parameter, lowcost, integrated of measurement and control for greenhouses. With the physical greenhouse-models, the proposed system is tested. The evaluation results showed the designed system obtained effective control performance with low power consumption, strong mobility and stability, the measured data can be uploaded to the PC for display in real-time. The diagram of experimental system is shown in Figure 7.



Fig. 7 The diagram of experimental system

A remote intelligent control system which has multi-parameter, low-cost, integrated of measurement and control is developed for greenhouse by using the ZigBee technology. The system has great practical significance for the intelligent control of greenhouses. However, the system only analyze and process data expect for observing the status of crop growth in real-time, using a video to monitor crop growth will truly achieve automatic operation and management, which is also the development direction of the next.

## References

- [1] Y.W. Zhong, Z.H. Ling, Q.Q. Wu: ZigBee Wireless Communication Technology and Investigation on Its Application, Process Automation Instrumentation, Vol. 26 (2005) No.6, p.5-9.
- [2] R.X. Jiang, K.Y. Lin, J.H. Wu etc: Study and Design on Monitoring and Controlling System for Greenhouse Group Based on ZigBee. Journal of Shanghai Jiaotong University: Agricultural Science Edition. , Vol. 26 (2008) No.5, p.440-444.
- [3] H. Du, J.K. Chen: Research on Design of Distributed Greenhouse Monitoring System Based on Bluetooth Technology, Process Automation Instrumentation, Vol. 26 (2005) No.3, p.19-22.

- 
- [4] D.L. Shen, Y.J. Meng, C. Lu etc: Monitoring and Control System of Greenhouse Based on Wi-Fi, Chinese Agricultural Mechanization, Vol. 1 (2012), p.162-165.
- [5] F. Pan: Application of RS232 Serial Port in Communication between PC and SCM, Modern Electronic Technology, Vol.35 (2012) No.13, p.69-71.
- [6] P. Tao: The Research of Greenhouses Intelligent Monitor System Based on ZigBee, Xihua University, 2012, p.22-25.
- [7] C.H. Wang: Solid State Relay and Its Application, Journal of Northwest Electric Power Technology, Vol.5 (2004), p.49-52.
- [8] Y.J. Wang. Office Environment Monitoring System Based on CC2530. Jilin University, 2012, 4-7.
- [9] J.W. Cui: The Design and Research of Greenhouses Wireless Temperature Monitoring System, Taiyuan University of Science and Technology, 2013, p.46-47.
- [10] T.H. Du, W.X. Yu, J.G. Lu: Communication Interface Design between DSP and PC, Computer Measurement and Control, Vol.10 (2002) No.5, p.327-329.
- [11] C. Liu, F. Wang, K. Shi, et al: Robust  $H^\infty$  Control for Satellite Attitude Control System with Uncertainties and Additive Perturbation, International Journal of Science, Vol.1 (2014), No.2, p.1-9.